



Green Mountain Window and Door Co.

Milestone Double Hung v2.2

Product Information

Unit Specifications	1.2
NFRC & Design Pressure Information	1.3 & 1.4
Egress & Clear Opening Information	1.5
Measurement Conversions	1.6

Elevations & Sections

General Elevation & Section Overview	1.7
Elevations: Double Hung	1.8
Elevations: Picture Window	1.9
Elevations: Double Hung Transom & Cottage Units	1.10
Section Details: Double Hung	1.11
Section Details: Picture Window	1.12
Section Details: Double Hung Transom	1.13
Section Details: Divided Lite Options	1.14
Daylight Opening Conversions	1.15
Elevations: 5/8" Standard Divided Lite Patterns	1.16
Elevations: 7/8" Standard Divided Lite Patterns	1.18

Angle Bay Assemblies

Section Details	1.20
-----------------------	------

NOTE:

All specifications and data are subject to change without notice.

Allow 1/16" tolerance on all measurements.

Some options and accessories are not covered in this manual. Contact your Green Mountain Representative for further assistance



Green Mountain Window and Door Co.

Unit Specifications

Frame:

- Pine wood interior and exterior standard. Options include South American Mahogany, Philippine Mahogany (Marenti), Douglas Fir, Western Red Cedar, Teak, or other. Optional species can be specified for specific parts only (sill, sill nose, casing, etc.)
- Frame width: 4 9/16"
- Frame thickness: 5/8"
- Sill: 14 degree bevel, 1" standard sill nose. Optional 2" "historic" sill nose
- Pine exterior parts are dipped in a water repellent preservative.

Sash:

- Pine wood interior and exterior standard. Options include South American Mahogany, Philippine Mahogany (Marenti), Douglas Fir, Western Red Cedar, Teak, or other.
- Check rail thickness: 1 5/8"
- Stile and top & bottom rail thickness: 1 1/4"
- Operating sash tilt in for easy cleaning. The top sash of reverse cottage windows can not be tilted in.
- Pine exterior parts are dipped in a water repellent preservative.

Interior and exterior finish:

- Bare wood interior white primed exterior standard
- Pre-finished exterior options. See your Green Mountain Window Representative for colors and availability.

Hardware:

- Standard sash lock and keeper: Truth cam lock in Bronze. Option finish: white.
- Upgraded sash lock and keeper: Colonial cam lock in Oil Rubbed Bronze, Nickel, Polished Chrome or Brass. Arts & Crafts pivot lock available in Brass only.
- Sash lift: Truth sash lift in Bronze. Option: finish to match lock choice.
- Balance system: block and tackle balance

Weatherstrip:

- Foam filled bulb on weatherstrip on top rail, bottom rail, and side jambs. Jamb weatherstrip is light beige.
- Leaf weatherstrip on head parting stop.

Jamb extension:

- Applied jamb extension available to match virtually any wall thickness
- Standard thickness: 21/32"

Insect Screens:

- Aluminum framed full screen with charcoal fiberglass mesh screening standard. Optional surround colors: Dark Bronze, Tan or Green. Optional mesh: charcoal aluminum, bright aluminum, or Gore Enlighten high visibility.
- Optional wood screen: full or half screens with charcoal fiberglass mesh screening. Species and finish to match window.
- Optional mesh: charcoal aluminum, bright aluminum, bright bronze, or Gore Enlighten high visibility.

Glass:

- Double strength glass sealed with Gray Duraseal warm edge spacer. Standard overall glass thickness on wood exterior units is 1/2" with wood exterior glazing bead. Optional 11/16" glass thickness with white vinyl exterior glazing bead.
- Glazing method: silicone wet seal interior and exterior
- Glazing types: single glass, insulating glass
- Option for black Duraseal warm edge spacer
- Standard insulating glass options include: (see NFRC ratings for performance comparison)
 - 1/2" regular insulating glass
 - 1/2" Low E with Argon gas fill
 - 1/2" Low E with Krypton gas fill
 - 11/16" regular insulating glass (white vinyl glazing bead on exterior)
 - 11/16" Low E with Argon (white vinyl glazing bead on exterior)
- Other glass options: tempered, laminated, obscure, mouth blown restoration (wavy), tinted, UL rated, any specified

Optional Divided Lites:

- Options include: 5/8" white flat airspace grille, 5/8" white profiled airspace grille, 7/8" removable stick grille (interior only), 7/8" removable full surround grille (interior only), 5/8" true divided lite (single glass only), 5/8" simulated divided lite (SDL) with or without spacer bar, 7/8" SDL with or without a spacer and 1 1/4" SDL with or without a spacer bar. Gray SDL spacer is standard with gray SDL tape. Optional black spacer and tape is used when black glass spacer option is chosen.
- See "section details: divided lites for muntin profiles" for standard cuts. Custom configurations are available

Green Mountain Window and Door Co.

NFRC Values						
Glazing Type and Thickness	U-Factor	CR-Value	SHGC	VT	R-Value	
Single Glass	.86	12	.63	.66	1.16	
Single Glass with TDL	.86	12	.57	.58	1.16	
Single Glass with TDL and Ext. EP	.47	44	.50	.53	2.13	
Single Glass with TDL and Ext. Low E EP	.40	32	.44	.49	2.50	
Single Glass with TDL and Int. EP	.46	45	.50	.53	2.17	
Single Glass with TDL and Int. Low E EP	.37	32	.44	.49	2.70	
Single Glass with TDL and Storm	.43	-	.50	.53	2.33	
Single Glass with TDL and Low E Storm	.32	-	.43	.49	3.13	
Single Glass with TDL and Laminated Storm	.42	-	.43	.52	2.38	
Single Glass with TDL, Ext. EP and Storm	.30	-	.45	.48	3.33	
Single Glass with TDL, Ext. EP and Low E Storm	.25	-	.39	.44	4.00	
Single Glass with TDL, Ext. Low E EP and Storm	.25	-	.40	.44	4.00	
Single Glass with TDL, Ext. Low E EP and Low E Storm	.21	-	.36	.41	4.76	
Single Glass with TDL, Int. EP and Storm	.30	-	.45	.48	3.33	
Single Glass with TDL, Int. EP and Low E Storm	.24	-	.39	.44	4.17	
Single Glass with TDL, Int. Low E EP and Storm	.25	-	.40	.44	4.00	
Single Glass with TDL, Int. Low E EP and Low E Storm	.21	-	.36	.41	4.76	
1/2" Glass Thickness						
1/2" Clear Insulated	.50	42	.56	.60	2.00	
1/2" Clear Insulated with SDL	.50	42	.50	.53	2.00	
1/2" Clear Insulated with SDL and Spacer	.52	40	.50	.53	1.92	
1/2" Low E / Argon	.35	52	.48	.55	2.70	
1/2" Low E / Argon with SDL	.35	52	.43	.49	2.70	
1/2" Low E / Argon with SDL and Spacer	.37	52	.43	.49	2.50	
1/2" Low E / Krypton	.28	57	.43	.49	3.13	
1/2" Low E / Krypton with SDL	.28	57	.43	.49	3.13	
1/2" Low E / Krypton with SDL and Spacer	.30	57	.43	.49	2.94	
1/2" Low E / Argon with Storm	.26	-	.45	.50	3.85	
1/2" Low E / Argon with SDL and Storm	.26	-	.40	.44	3.85	
1/2" Low E / Argon with SDL, Spacer and Storm	.27	-	.40	.44	3.70	
1/2" Low E / Krypton with Storm	.23	-	.44	.50	4.35	
1/2" Low E / Krypton with SDL and Storm	.23	-	.39	.44	4.35	
1/2" Low E / Krypton with SDL, Spacer and Storm	.24	-	.39	.44	4.17	

NFRC Values, cont'd						
Glazing Type and Thickness	U-Factor	CR-Value	SHGC	VT	R-Value	
1/2" Low E / Argon with Low E Storm	.22	-	.41	.46	4.55	
1/2" Low E / Argon with SDL and Low E Storm	.22	-	.36	.41	4.55	
1/2" Low E / Argon with SDL, Spacer and Low E Storm	.23	-	.36	.41	4.35	
1/2" Low E / Krypton with Low E Storm	.19	-	.40	.46	5.26	
1/2" Low E / Krypton with SDL and Low E Storm	.19	-	.36	.41	5.26	
1/2" Low E / Krypton with SDL, Spacer and Low E Storm	.20	-	.36	.41	5.00	
1/2" Low E / Argon with Low E Laminated Storm	.21	-	.36	.45	4.76	
1/2" Low E / Argon with SDL and Low E Laminated Storm	.21	-	.33	.40	4.76	
1/2" Low E / Argon with SDL, Spacer and Low E Laminated Storm	.22	-	.33	.40	4.55	
1/2" Low E / Krypton with Low E Laminated Storm	.19	-	.36	.45	5.26	
1/2" Low E / Krypton with SDL and Low E Laminated Storm	.19	-	.32	.40	5.26	
1/2" Low E / Krypton with SDL, Spacer and Low E Laminated Storm	.20	-	.32	.40	5.00	
11/16" Glass Thickness						
11/16" Insulated Glass	.46	43	.56	.60	2.17	
11/16" Insulated Glass with SDL	.46	43	.50	.53	2.17	
11/16" Insulated Glass with SDL and Spacer	.46	43	.50	.53	2.17	
11/16" Low E Glass with Argon	.32	55	.48	.55	3.13	
11/16" Low E Glass with Argon and SDL	.32	55	.43	.49	3.13	
11/16" Low E Glass with Argon, SDL and Spacer	.33	55	.43	.49	3.03	

= South

Design Pressure Values are based on a 44" x 60" window (per the industry test standard). Unit #1 is based on our standard interior sill stop. Unit #2 has an optional 3/4" tall sill stop. Many installers apply a 3/4" tall stool cap in the place of our standard sill stop. Overall Design Pressure:

Unit #1 – DP 35

Unit #2 – DP 40

Specific Test Results for ANSI/AAMA/NWDA/I.S.2:

	Results:	Allowed:
Air Infiltration – ASTM E283	.11 scfm/ft ²	.30 scfm/ft ²
Water Resistance – ASTM E547 Unit #1 5.25 psf	Pass	No Leakage
Water Resistance – ASTM E547 Unit #2 6.00 psf	Pass	No Leakage
Uniform Structural Load – ASTM E330 Unit #1 22.5 psf	Pos .020 in	.164 in
“	Neg .012 in	.164 in
Uniform Structural Load – ASTM E330 Unit #2 60 psf	Pos .065 in	.164 in
“	Neg .0005 in	.164 in
Forced Entry Resistance – ASTM F588 Grade 10	Pass	No Entry
Operating Force – ASTM E2068	17 / 17 lb/f	30 lb/f
Deglazing – ASTM E987	0%	<100%

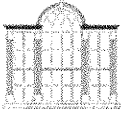

Green Mountain Window and Door Co.

Egress and Clear Opening Information

Size	Clear Opening Width	Clear Opening Height	Square Foot Opening	Size	Clear Opening Width	Clear Opening Height	Square Foot Opening
16x12	17 7/8	11	1.37	28x26	29 7/8	25	5.19
16x14	17 7/8	13	1.61	28x28**	29 7/8	27 1/2	5.71
16x16	17 7/8	15	1.86	28x30*	29 7/8	29	6.02
16x18	17 7/8	17	2.11	28x32*	29 7/8	31	6.43
16x20	17 7/8	19	2.36	28x34*	29 7/8	33	6.85
16x22	17 7/8	21	2.61	28x36*	29 7/8	35	7.26
16x24	17 7/8	23	2.86	30x12	31 7/8	11	2.43
16x26	17 7/8	25	3.08	30x14	31 7/8	13	2.88
16x28	17 7/8	27	3.35	30x16	31 7/8	15	3.32
16x30	17 7/8	29	3.60	30x18	31 7/8	17	3.76
16x32	17 7/8	31	3.85	30x20	31 7/8	19	4.21
16x34	17 7/8	33	4.10	30x22	31 7/8	21	4.65
16x36	17 7/8	35	4.34	30x24	31 7/8	23	5.09
20x12	21 7/8	11	1.67	30x26	31 7/8	25	5.53
20x14	21 7/8	13	1.98	30x28*	31 7/8	27	5.98
20x16	21 7/8	15	2.28	30x30*	31 7/8	29	6.42
20x18	21 7/8	17	2.58	30x32*	31 7/8	31	6.86
20x20	21 7/8	19	2.89	30x34*	31 7/8	33	7.30
20x22	21 7/8	21	3.19	30x36*	31 7/8	35	7.75
20x24	21 7/8	23	3.49	32x12	33 7/8	11	2.59
20x26	21 7/8	25	3.80	32x14	33 7/8	13	3.06
20x28	21 7/8	27	4.10	32x16	33 7/8	15	3.53
20x30	21 7/8	29	4.41	32x18	33 7/8	17	4.00
20x32	21 7/8	31	4.71	32x20	33 7/8	19	4.47
20x34	21 7/8	33	5.01	32x22	33 7/8	21	4.94
20x36	21 7/8	35	5.32	32x24	33 7/8	23	5.41
24x12	25 7/8	11	1.98	32x26*	33 7/8	25	5.88
24x14	25 7/8	13	2.32	32x28*	33 7/8	27	6.35
24x16	25 7/8	15	2.70	32x30*	33 7/8	29	6.82
24x18	25 7/8	17	3.05	32x34*	33 7/8	33	7.76
24x20	25 7/8	19	3.41	32x36*	33 7/8	35	8.20
24x22	25 7/8	21	3.77	36x12	37 7/8	11	2.89
24x24	25 7/8	23	4.13	36x14	37 7/8	13	3.42
24x26	25 7/8	25	4.49	36x16	37 7/8	15	3.95
24x28	25 7/8	27	4.85	36x18	37 7/8	17	4.47
24x30	25 7/8	29	5.21	36x20	37 7/8	19	5.00
24x32	25 7/8	31	5.57	36x22	37 7/8	21	5.52
24x34*	25 7/8	33	5.93	36x24*	37 7/8	23	6.05
24x36*	25 7/8	35	6.29	36x26*	37 7/8	25	6.58
26x12	27 7/8	11	2.13	36x28*	37 7/8	27	7.10
26x14	27 7/8	13	2.52	36x30*	37 7/8	29	7.63
26x16	27 7/8	15	2.90	36x32*	37 7/8	31	8.15
26x18	27 7/8	17	3.29	36x34*	37 7/8	33	8.68
26x20	27 7/8	19	3.68	36x36*	37 7/8	35	9.21
26x22	27 7/8	21	4.07	40x12	41 7/8	11	3.20
26x24	27 7/8	23	4.45	40x14	41 7/8	13	3.78
26x26	27 7/8	25	4.84	40x16	41 7/8	15	4.36
26x28	27 7/8	27	5.23	40x18	41 7/8	17	4.94
26x30	27 7/8	29	5.61	40x20	41 7/8	19	5.53
26x32*	27 7/8	31	6.00	40x22	41 7/8	21	6.11
26x34*	27 7/8	33	6.39	40x24*	41 7/8	23	6.69
26x36*	27 7/8	35	6.78	40x26*	41 7/8	25	7.27
28x12	29 7/8	11	2.28	40x28*	41 7/8	27	7.85
28x14	29 7/8	13	2.70	40x30*	41 7/8	29	8.43
28x16	29 7/8	15	3.11	40x32*	41 7/8	31	9.01
28x18	29 7/8	17	3.53	40x34*	41 7/8	33	9.60
28x20	29 7/8	19	3.94	40x36*	41 7/8	35	10.18
28x22	29 7/8	21	4.36				
28x24	29 7/8	23	4.77				

*These units meet national egress codes for fire evacuation. Local codes may vary.

** The 28x28 can be ordered to meet 5.7 sp. Ft. by specifying 28x28E.

Note on optional locks: some optional locks or aftermarket locks will keep bottom sash from rising all the way up. This will decrease the amount of clear opening. Please contact you Green Mountain Window Representative for details.



Green Mountain Window and Door Co.

Measurement Conversions

“Size” used for conversion purposes is the unit name.

Example: 32x24 double hung has a “size” of 32 wide and 24 high.

Double Hung:

	<u>Width</u>	<u>Height</u>
For Daylight Opening:	“Size” – 1/2”	“Size” – 1/2”
For Sash Opening:	“Size” + 4”	“Size” x 2 + 6”
For Frame Size:	“Size” + 5 5/16”	“Size” x 2 + 8 7/8”
For Rough Opening:	“Size” + 6 5/16”	“Size” x 2 + 9 3/8”

Rough Openings of Mullled Units:

Double Wide Unit:	(Single RO x2) -1”	No Conversion Necessary
Triple Wide Unit:	(Single RO x3) -2”	No Conversion Necessary
Four Wide Unit:	(Single RO x4) -3”	No Conversion Necessary

Picture Windows:

	<u>Width</u>	<u>Height</u>
For Daylight Opening:	“Size” – 5/8”	“Size” – 5/8”
For Sash Opening:	“Size” + 4”	“Size” + 5”
For Frame Size:	“Size” + 5 5/16”	“Size” + 7 7/8”
For Rough Opening:	“Size” + 6 5/16”	“Size” + 8 3/8”

Rough Openings of Mullled Units:

Double Wide Unit:	(Single RO x2) -1”	No Conversion Necessary
Triple Wide Unit:	(Single RO x3) -2”	No Conversion Necessary
Four Wide Unit:	(Single RO x4) -3”	No Conversion Necessary

Double Hung Transoms:

	<u>Width</u>	<u>Height</u>
For Daylight Opening:	“Size” – 1/2”	“Size” + 1/8”
For Sash Opening:	“Size” + 4”	“Size” + 4 3/8”
For Frame Size:	“Size” + 5 5/16”	“Size” + 7”
For Rough Opening:	“Size” + 6 5/16”	“Size” + 7 1/2”

Note: If transom is to be directly mulled above a double hung add the frame height of the transom to the rough opening height of the double hung for overall rough opening.











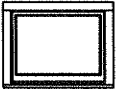

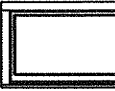
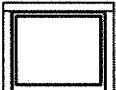
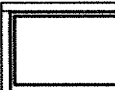

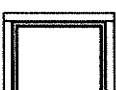





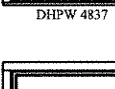
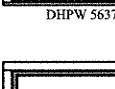

Rough Openings of Mullled Units:



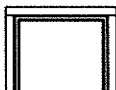

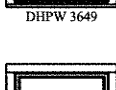
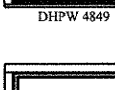
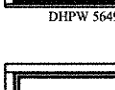















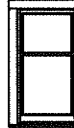





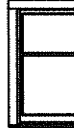









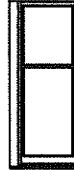
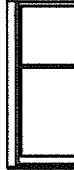





Double Wide Unit:	(Single RO x2) -1”	No Conversion Necessary
Triple Wide Unit:	(Single RO x3) -2”	No Conversion Necessary
Four Wide Unit:	(Single RO x4) -3”	No Conversion Necessary

Glass Size Sash Opening Frame Rough Opening	16" 1' 0-1/4" 1' 10-1/4"	20" 1' 4" 2' 2-1/4"	24" 1' 8" 2' 6-1/4"	26" 1' 10-1/4" 2' 8-1/4"	28" 1' 12-1/4" 2' 10-1/4"	30" 1' 14-1/4" 3' 0-1/4"	32" 1' 16-1/4" 3' 2-3/4"	36" 1' 20-1/4" 3' 6-1/4"	40" 1' 24-1/4" 3' 10-1/4"	Glass Size Sash Opening Frame Rough Opening	36" 3' 0-1/4" 3' 6-1/4"	48" 3' 6-1/4" 4' 6-1/4"	56" 3' 11-1/4" 5' 2-1/4"
MDH 1612	MDH 2012	MDH 2412	MDH 2612	MDH 2812	MDH 3012	MDH 3212	MDH 3612	MDH 4012	DHPW 3625	DHPW 4825	DHPW 5625		
MDH 1614	MDH 2014	MDH 2414	MDH 2614	MDH 2814	MDH 3014	MDH 3214	MDH 3614	MDH 4014	DHPW 3629	DHPW 4829	DHPW 5629		
MDH 1616	MDH 2016	MDH 2416	MDH 2616	MDH 2816	MDH 3016	MDH 3216	MDH 3616	MDH 4016	DHPW 3633	DHPW 4833	DHPW 5633		
MDH 1618	MDH 2018	MDH 2418	MDH 2618	MDH 2818	MDH 3018	MDH 3218	MDH 3618	MDH 4018	DHPW 3637	DHPW 4837	DHPW 5637		
MDH 1620	MDH 2020	MDH 2420	MDH 2620	MDH 2820	MDH 3020	MDH 3220	MDH 3620	MDH 4020	DHPW 3641	DHPW 4841	DHPW 5641		
MDH 1622	MDH 2022	MDH 2422	MDH 2622	MDH 2822	MDH 3022	MDH 3222	MDH 3622	MDH 4022	DHPW 3645	DHPW 4845	DHPW 5645		
MDH 1624	MDH 2024	MDH 2424	MDH 2624	MDH 2824	MDH 3024	MDH 3224	MDH 3624E	MDH 4024E	DHPW 3649	DHPW 4849	DHPW 5649		
MDH 1626	MDH 2026	MDH 2426	MDH 2626	MDH 2826	MDH 3026	MDH 3226E	MDH 3626E	MDH 4026E	DHPW 3653	DHPW 4853	DHPW 5653		
MDH 1628	MDH 2028	MDH 2428	MDH 2628	MDH 2828E	MDH 3028E	MDH 3228E	MDH 3628E	MDH 4028E	DHPW 3657	DHPW 4857	DHPW 5657		
MDH 1630	MDH 2030	MDH 2430	MDH 2630	MDH 2830E	MDH 3030E	MDH 3230E	MDH 3630E	MDH 4030E	DHPW 3661	DHPW 4861	DHPW 5661		
MDH 1632	MDH 2032	MDH 2432	MDH 2632E	MDH 2832E	MDH 3032E	MDH 3232E	MDH 3632E	MDH 4032E					
MDH 1634	MDH 2034	MDH 2434E	MDH 2634E	MDH 2834E	MDH 3034E	MDH 3234E	MDH 3634E	MDH 4034E					
MDH 1636	MDH 2036	MDH 2436E	MDH 2636E	MDH 2836E	MDH 3036E	MDH 3236E	MDH 3636E	MDH 4036E					

Rough Openings of Muller Units
 Double Wide: (Single RO x 2) -1"
 Triple Wide: (Single RO x 3) -2"
 Four Wide: (Single RO x 4) -3"

Glass Size Sash Opening Frame Rough Opening	16" 20" 1' 9-1/4"	20" 24" 2' 2-1/4"	24" 28" 2' 5-1/4"	26" 30" 2' 8-1/4"	28" 32" 2' 10-1/4"	30" 34" 2' 11-1/4"	32" 36" 3' 2-1/4"	36" 40" 3' 5-1/4"	40" 44" 3' 9-1/4"
12" 36" 2' 2' 3/8"									
14" 34" 3' 3 1/8"									
16" 38" 3' 3 5/8"									
18" 42" 3' 3 7/8"									
20" 46" 4' 4 1/8"									
22" 50" 4' 4 5/8"									
24" 54" 4' 5 1/8"									
26" 58" 5' 5 5/8"									
28" 62" 5' 6 1/8"									
30" 66" 5' 6 5/8"									
32" 70" 6' 7 1/8"									
34" 74" 6' 7 5/8"									
36" 78" 6' 8 1/8"									

Glass Size	36"	48"	56"
Sash Opening	40"	52"	60"
Frame	3' 5-1/4"	4' 5-1/4"	5' 1-1/4"
Rough Opening	3' 6-1/4"	4' 6-1/4"	5' 2-1/4"
25" 30" 3' 6-7/8" 2' 9-3/8"	 DHPW 3625	 DHPW 4825	 DHPW 5625
29" 34" 3' 0-7/8" 3' 1-3/8"	 DHPW 3629	 DHPW 4829	 DHPW 5629
33" 38" 3' 4-7/8" 3' 5-3/8"	 DHPW 3633	 DHPW 4833	 DHPW 5633
37" 42" 3' 8-7/8" 3' 9-3/8"	 DHPW 3637	 DHPW 4837	 DHPW 5637
41" 46" 4' 0-7/8" 4' 1-3/8"	 DHPW 3641	 DHPW 4841	 DHPW 5641
45" 50" 4' 4-7/8" 4' 5-3/8"	 DHPW 3645	 DHPW 4845	 DHPW 5645
49" 54" 4' 8-7/8" 4' 9-3/8"	 DHPW 3649	 DHPW 4849	 DHPW 5649
53" 58" 5' 0-7/8" 5' 1-3/8"	 DHPW 3653	 DHPW 4853	 DHPW 5653
57" 62" 5' 4-7/8" 5' 5-3/8"	 DHPW 3657	 DHPW 4857	 DHPW 5657
61" 66" 5' 8-7/8" 5' 9-3/8"	 DHPW 3661	 DHPW 4861	 DHPW 5661

Class Size	16"	20"	24"	26"	28"	30"	32"	36"	40"
Sash Opening	1' 9-1/4"	2' 1-1/4"	2' 5-1/4"	2' 7-1/4"	2' 9-1/4"	2' 11-1/4"	3' 1-1/4"	3' 5-1/4"	3' 9-1/4"
Frame	1' 10-1/4"	2' 2-1/4"	2' 6-1/4"	2' 8-1/4"	2' 10-1/4"	3' 0-1/4"	3' 2-1/4"	3' 6-1/4"	3' 10-1/4"
Rough Opening	8 7/8"	1' 4-1/2"	1' 8"	1' 10"	1' 11-1/2"	2' 0"	2' 2-1/2"	2' 6-1/2"	2' 10-1/2"
									
	DHTR 169	DHTR 209	DHTR 249	DHTR 269	DHTR 289	DHTR 309	DHTR 329	DHTR 369	DHTR 409
									
	MDH 1616/24	MDH 2016/24	MDH 2416/24	MDH 2616/24	MDH 2816/24	MDH 3016/24	MDH 3216/24	MDH 3616/24	MDH 4016/24
									
	MDH 1624/16	MDH 2024/16	MDH 2424/16	MDH 2624/16	MDH 2824/16	MDH 3024/16	MDH 3224/16	MDH 3624/16	MDH 4024/16
									
	MDH 1624/36	MDH 2024/36	MDH 2424/36	MDH 2624/36	MDH 2824/36	MDH 3024/36	MDH 3224/36	MDH 3624/36	MDH 4024/36
									
	MDH 1636/24	MDH 2036/24	MDH 2436/24	MDH 2636/24	MDH 2836/24	MDH 3036/24	MDH 3236/24	MDH 3636/24	MDH 4036/24

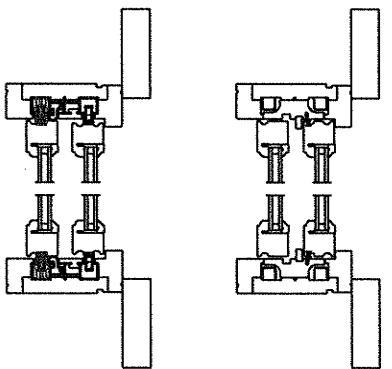
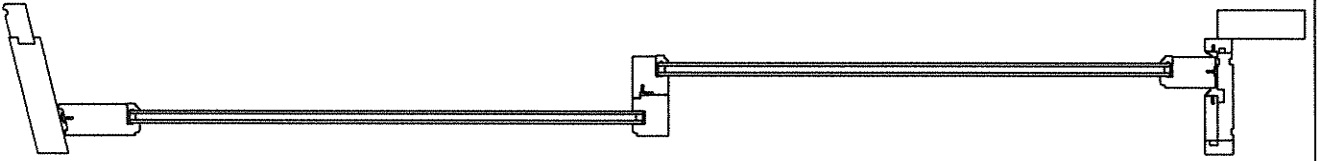

MDH Cross Sections

Green Mountain Window and Door Co.

92 Park Street, Rutland, Vermont 05701

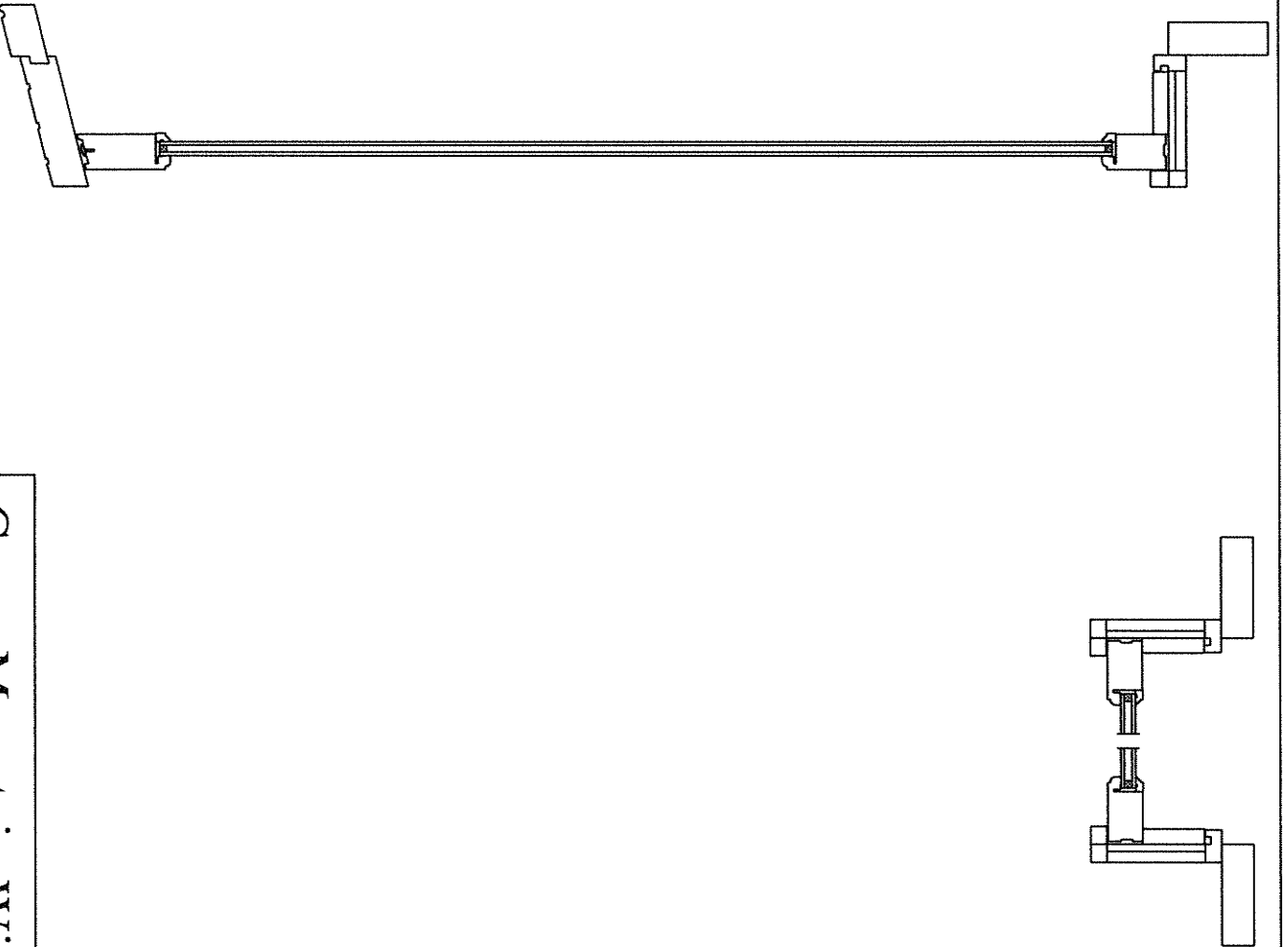

Double Hung Picture Cross Sections

Green Mountain Window and Door Co.

92 Park Street, Rutland, Vermont 05701

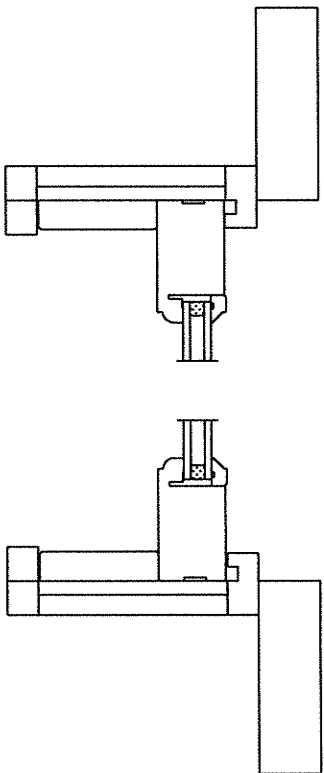
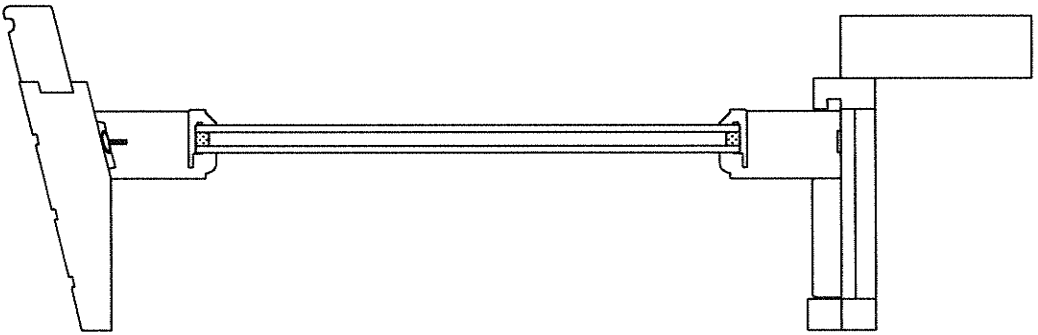

Double Hung Transom Cross Sections

Green Mountain Window and Door Co.

92 Park Street, Rutland, Vermont 05701

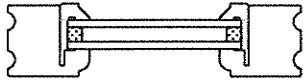

I.G., No Lites
Wood Bead

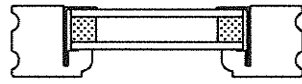

I.G., No Lites
Vinyl Bead

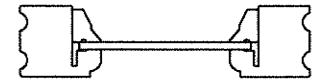

No Lites
Single Glass

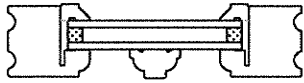

7/8" Grille

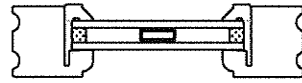

Flat Airspace

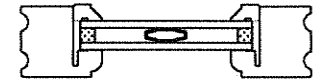

Profile Airspace

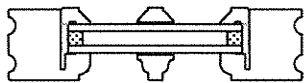

5/8" SDL

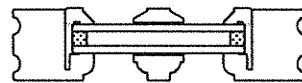

7/8" SDL

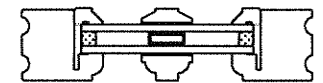

7/8" SDL
with Spacer Bar



5/8" SDL
with Spacer Bar



1 1/4" SDL



1 1/4" SDL
with Spacer Bar

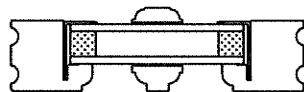

I.G., 7/8" SDL
Vinyl Bead



I.G., 7/8" SDL
with Spacer Bar
Vinyl Bead



5/8" TDL
Single Glass
Putty Glaze

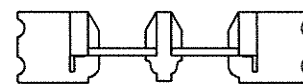

5/8" TDL
Single Glass
Wood Bead

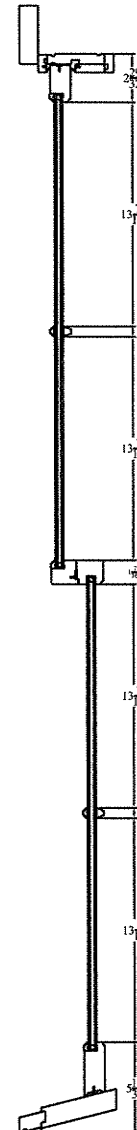
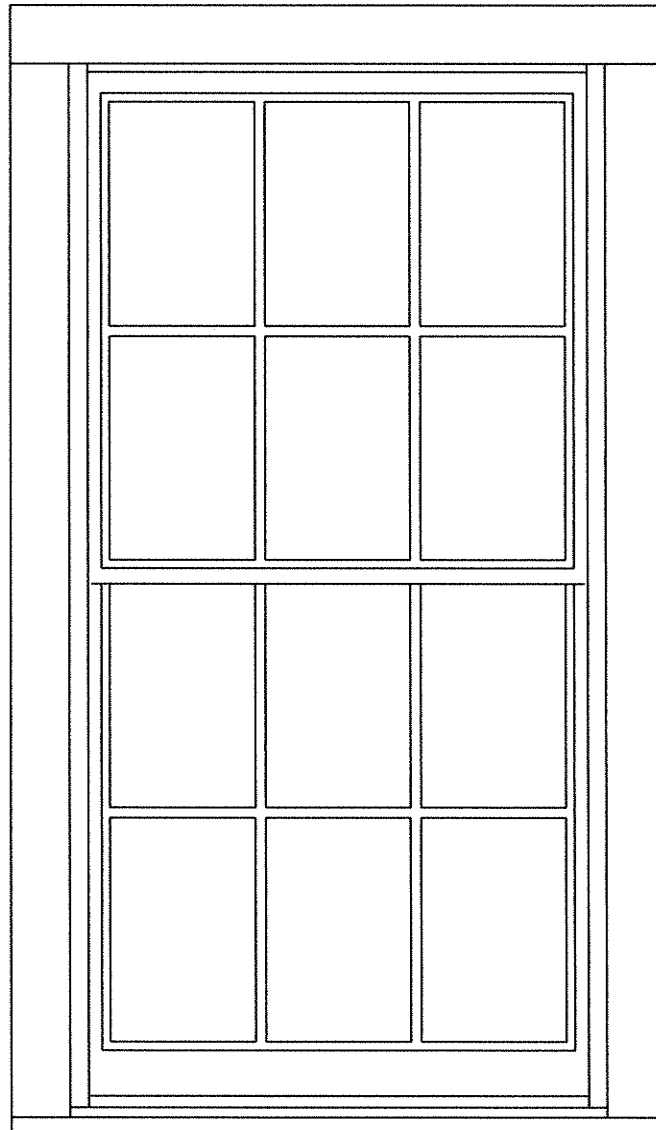
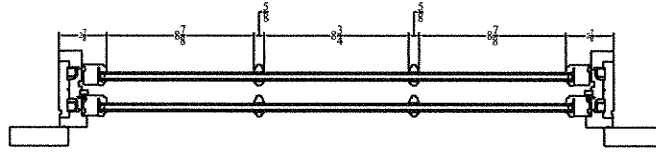











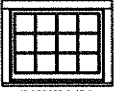
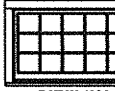
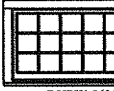
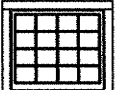
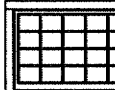
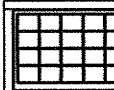
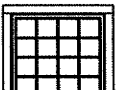
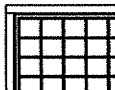
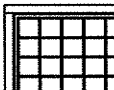
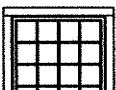
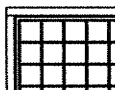
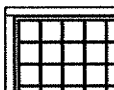
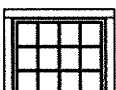

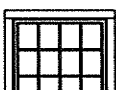
MDH 2828

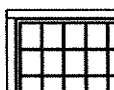
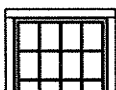
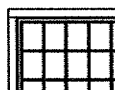

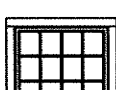

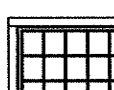
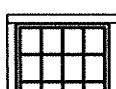
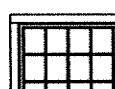
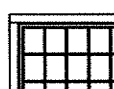















































































































Note: the example above only applies to a 28 x 28 with 7/8" muntins in a 6/6 pattern.
 For all other sizes and configurations: determine the overall daylight opening of each sash (without lites) with the formulas on 1.5. Then multiply the number of bars by the bar width and deduct that number from that overall daylight. Divide this number by the number of lites for daylight of each lite.











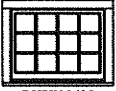

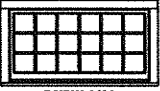
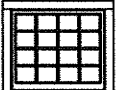
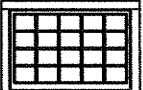
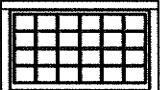
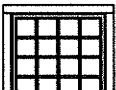

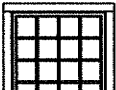

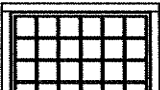
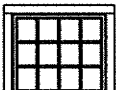

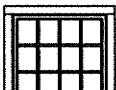

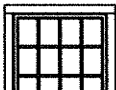
$$\frac{\text{Overall DLO} - (\text{sum of all bar widths})}{\text{Number of Lites}}$$

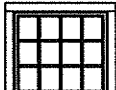
1.15

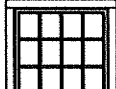
Glass Size Sash Opening Frame Rough Opening	16"	20"	24"	26"	28"	30"	32"	36"	40"
16" 30" 3" 10-1/4"									
14" 34" 3" 11-7/8"									
16" 36" 3" 11-7/8"									
18" 42" 3" 11-7/8"									
20" 46" 4" 11-1/8"									
22" 50" 4" 11-7/8"									
24" 54" 4" 11-7/8"									
26" 58" 5" 11-7/8"									
28" 62" 5" 11-7/8"									
30" 66" 5" 11-7/8"									
32" 70" 6" 11-7/8"									
34" 74" 6" 11-7/8"									
36" 78" 6" 11-7/8"									

	Glass Size Sash Opening Frame Rough Opening	36" 40" 3' 5-1/4" 3' 6-1/4"	48" 52" 4' 5-1/4" 4' 6-1/4"	56" 60" 5' 1-1/4" 5' 2-1/4"
	25" 30" 3' 2-7/8" 2' 9-3/8"			
	29" 34" 3' 0-7/8" 3' 1-3/8"			
	33" 38" 3' 4-7/8" 3' 5-3/8"			
	37" 42" 3' 8-7/8" 3' 9-3/8"			
	41" 46" 4' 0-7/8" 4' 1-3/8"			
	45" 50" 4' 4-7/8" 4' 5-3/8"			
	49" 54" 4' 8-7/8" 4' 9-3/8"			
	53" 58" 5' 0-7/8" 5' 1-3/8"			
	57" 62" 5' 4-7/8" 5' 5-3/8"			
	61" 66" 5' 8-7/8" 5' 9-3/8"			

Glass Size Sash Opening Frame Rough Opening	16"	20"	24"	26"	28"	30"	32"	36"	40"
12" 30-7/8" 2-1/4" 10-1/4"	 MDH 1612	 MDH 2012	 MDH 2412	 MDH 2612	 MDH 2812	 MDH 3012	 MDH 3212	 MDH 3612	 MDH 4012
14" 34-7/8" 3-1/8" 10-1/4"	 MDH 1614	 MDH 2014	 MDH 2414	 MDH 2614	 MDH 2814	 MDH 3014	 MDH 3214	 MDH 3614	 MDH 4014
16" 38-7/8" 3-5/8" 10-1/4"	 MDH 1616	 MDH 2016	 MDH 2416	 MDH 2616	 MDH 2816	 MDH 3016	 MDH 3216	 MDH 3616	 MDH 4016
18" 42-7/8" 3-9/8" 10-1/4"	 MDH 1618	 MDH 2018	 MDH 2418	 MDH 2618	 MDH 2818	 MDH 3018	 MDH 3218	 MDH 3618	 MDH 4018
20" 46-7/8" 4-1/8" 10-1/4"	 MDH 1620	 MDH 2020	 MDH 2420	 MDH 2620	 MDH 2820	 MDH 3020	 MDH 3220	 MDH 3620	 MDH 4020
22" 50-7/8" 4-5/8" 10-1/4"	 MDH 1622	 MDH 2022	 MDH 2422	 MDH 2622	 MDH 2822	 MDH 3022	 MDH 3222	 MDH 3622	 MDH 4022
24" 54-7/8" 4-9/8" 10-1/4"	 MDH 1624	 MDH 2024	 MDH 2424	 MDH 2624	 MDH 2824	 MDH 3024	 MDH 3224	 MDH 3624E	 MDH 4024E
26" 58-7/8" 5-1/8" 10-1/4"	 MDH 1626	 MDH 2026	 MDH 2426	 MDH 2626	 MDH 2826	 MDH 3026	 MDH 3226E	 MDH 3626E	 MDH 4026E
28" 62-7/8" 5-5/8" 10-1/4"	 MDH 1628	 MDH 2028	 MDH 2428	 MDH 2628	 MDH 2828E	 MDH 3028E	 MDH 3228E	 MDH 3628E	 MDH 4028E
30" 66-7/8" 6-1/8" 10-1/4"	 MDH 1630	 MDH 2030	 MDH 2430	 MDH 2630	 MDH 2830E	 MDH 3030E	 MDH 3230E	 MDH 3630E	 MDH 4030E
32" 70-7/8" 6-5/8" 10-1/4"	 MDH 1632	 MDH 2032	 MDH 2432	 MDH 2632E	 MDH 2832E	 MDH 3032E	 MDH 3232E	 MDH 3632E	 MSH 4032E
34" 74-7/8" 6-9/8" 10-1/4"	 MDH 1634	 MDH 2034	 MDH 2434E	 MDH 2634E	 MDH 2834E	 MDH 3034E	 MDH 3234E	 MDH 3634E	 MSH 4034E
36" 78-7/8" 6-5/8" 10-1/4"	 MDH 1636	 MDH 2036	 MDH 2436E	 MDH 2636E	 MDH 2836E	 MDH 3036E	 MDH 3236E	 MDH 3636E	 MSH 4036E

	Glass Size Sash Opening Frame Rough Opening	36" 40" 3'-1/4" 3'-6-1/4"	48" 52" 4'-5-1/4" 4'-6-1/4"	56" 60" 5'-1-1/4" 5'-2-1/4"
	25" 30" 3'-7/8" 3'-2-3/8"			
	29" 34" 3'-0-7/8" 3'-1-3/8"			
	33" 38" 3'-4-7/8" 3'-5-3/8"			
	37" 42" 3'-8-7/8" 3'-9-3/8"			
	41" 46" 4'-0-7/8" 4'-1-3/8"			
	45" 50" 4'-4-7/8" 4'-5-3/8"			
	49" 54" 4'-8-7/8" 4'-9-3/8"			
	53" 58" 5'-0-7/8" 5'-1-3/8"			
	57" 62" 5'-4-7/8" 5'-5-3/8"			
	61" 66" 5'-8-7/8" 5'-9-3/8"			

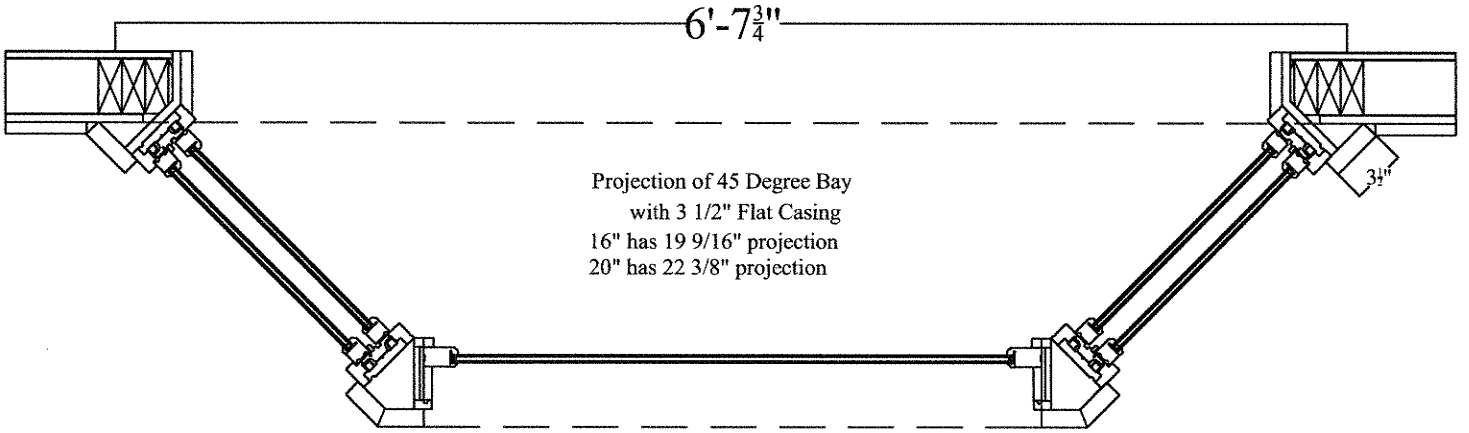

Projection of 45 Degree Bay
 with 3 1/2" Flat Casing
 16" has 19 9/16" projection
 20" has 22 3/8" projection

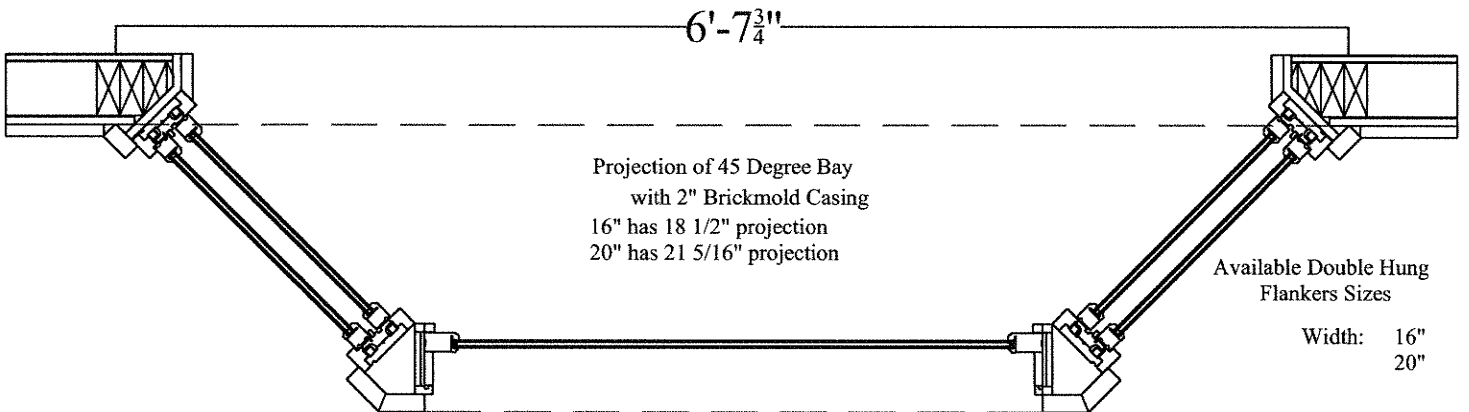

Projection of 45 Degree Bay
 with 2" Brickmold Casing
 16" has 18 1/2" projection
 20" has 21 5/16" projection

Available Double Hung
 Flankers Sizes

Width: 16"
 20"

Available Picture Window Sizes

Width: 36"	Height: 29"
48"	33"
56"	41"
	45"
	49"
	53"
	57"